

Steel and Metal
Bandsaw Machines
Mössner REKORD

www.moessner-kg.de

Analysieren. Entwickeln. Machen.



MÖSSNER BANDSAW MACHINES

100 YEARS EXPERIENCE IN CUTTING



For good reason Mössner Bandsaw Machines are used in all sectors of industry, mainly in the metal processing industry, for a wide range of cutting solutions.

Stable and low-vibration machine bodies, a powerful and at the same time efficient drive, solid mechanics, electronics and workmanship are characteristic features of all Mössner Bandsaw Machines. Thus, our machines guarantee quiet running, a long service life and longevity.

Mössner REKORD standard machines are designed and manufactured exclusively in our plant in Eschach and stand for quality "made in Germany".

Our bandsaw machines can be used universally, providing flexibility due to a large range of accessories and special equipment so that the machine can be specifically equipped for your requirements.

Do you need to cut unusual dimensions, workpieces or materials?
We would be pleased to test your workpieces in our test department.

Our goal is to design our bandsaw machines as efficient as possible by means of tools and special equipment to find an optimum solution for your specific needs.

Our team is ready to give advice on your particular demands – just call us!

YOUR CONTACT AT MÖSSNER

August Mössner GmbH + Co. KG

Hohenstauferstraße 3
73569 Eschach - Germany

Phone +49 7175 99806-0
Fax +49 7175 99806-41
Website: www.moessner-kq.de



Sales standard machines

Ms. Ingrid Quintin

Phone no.: +49 7175 99806-72

E-mail: IngridQuintin@moessner-kq.de

Sales special machinery

Mr. Christian Kunz
Sales Manager

Phone no.: +49 7175 99806-86

E-mail: ChristianKunz@moessner-kq.de

Mr. Michael Munz

Technical sales Germany/Austria/Switzerland

Phone no.: +49 7175 99806-11

E-mail: MichaelMunz@moessner-kq.de

Mr. Simon Lojewski

Technical sales International

Phone no.: +49 7175 99806-82

E-mail: SimonLojewski@moessner-kq.de

Mr. Philipp Staudenecker

Project planning

Phone no.: +49 7175 99806-69

E-mail: PhilippStaudenecker@moessner-kq.de

Sales assistance

Ms. Simone Hieber

Phone no.: +49 7175 99806-39

E-mail: SimoneHieber@moessner-kq.de

Spare parts sales

Ms. Simone Markowetz

Phone no.: +49 7175 99806-43

E-mail: SimoneMarkowetz@moessner-kq.de









Ms. Tatjana Tietze

Phone no.: +49 7175 99806-64

E-mail: TatjanaTietze@moessner-kq.de

OUR PARTNERS



<p>China</p> 	<p>Beijing RHX Technology Development Co. Ltd. Room 103, NO.215, Anshun Street, Tongzhou District Beijing 101100, China Phone +86-10-51349892, Fax +86-10-51349893 yuyanqi@rhx.com.cn, www.rhx.com.cn</p>
<p>USA</p> 	<p>Reich Companies PO BOX 218-4850, Commerce Drive 35173 Trussville Alabama, USA Phone 001.205.655.2121, Fax 001.205.655.2123 email@reichcompanies.com, www.reichcompanies.com</p>
<p>Switzerland</p>   <p>Werkzeugmaschinen / Machines-outils</p>	<p>Springmann Neuchâtel Route des Falaises 110, 2008 Neuchâtel, Switzerland Phone +41 32 729 1122, Fax +41 32 725 0101 neuchatel@springmann.ch http://www.springmann.com/f/homepage.php</p> <p>Springmann Niederbüren Staatsstraße 10, 9246 Niederbüren Switzerland Phone +41 71 424 2600, Fax +41 71 424 2660 niederburen@springmann.ch</p>
<p>Netherlands</p>  	<p>Van Hoorn Machining De Run 4338, 5503 LN Veldhoven, Netherlands Phone: +31 40-2540907, Fax: +31 40-2546788 info@vanhoornmachining.com, www.vanhoornmachining.com</p>
<p>Sweden</p> 	<p>AB Systemverktyg Johan Skyttes väg 201, 125 34 Älvsjö, Sweden Phone +46-8999200, Fax +46-87492815 http://www.systemverktyg.se/</p>
<p>Spain</p> 	<p>Hossel, Hermann Otto Suderow, S.L Las Mercedes 31, 1º, dpto. 10, Edificio Abra 3 48930 Las Arenas, Vizcaya, Spain Tel. +34 94 480 00 18, Fax +34 94 431 61 35 info@hossel.com, www.hossel.com</p>
<p>Mexico</p> 	<p>Kontrolable S.A. de C.V. Segunda Avenida #977, Colonia Zimix, Santa Catarina, Nuevo León 66358, Mexico Phone +52 (81) 20 86 5510, contacto@kontrolable.com, www.kontrolable.com</p>

OVERVIEW BANDSAWS MÖSSNER REKORD PRODUCT PORTFOLIO

Bandsaw type	Cutting speed m/min.	Standard tables		Max. Throat		Sizes Bandsaw mm	Motor power kW
		Size mm	Load max. kg	Height mm	Width mm		
SSF420 4-speed transmission	12-1900	600 x 600	150	230	410	L 1215 W 750 H 1860	2,2
SSF520 2-speed transmission	22-150 and 338-2280	740 x 785	250	520	510	L 1565 W 970 H 2600	5,5
Flange bearing	500-2000						
SSF630 2-speed transmission	27-142 and 410-2200	740 x 785	250	460	605	L 1820 W 970 H 2560	5,5
Flange bearing	500-2000						
SSF630 reinforced design 2-speed transmission	30-180 and 342-2000	740 x 785	250	460	605	L 1820 W 970 H 2560	11
Flange bearing	500-2000						
SSF801 2-speed transmission	26-180 and 290-2000	960 x 1000	750	670	785	L 2240 W 1080 H 3000	11
Flange bearing	500-2000						
SSF1600 2-speed transmission	22-150 and 338-2280	740 x 785	250	400	1600	L 3100 W 1060 H 2320	5,5
Flange bearing	500-2000						

STEEL AND METAL BANDSAW MACHINES

MÖSSNER REKORD SSF420



Technical details:

- Bandsaw machine column in stable grey cast construction
- Cutting speed adjustable via frequency converter and three-phase motor with potentiometer
- 4-speed manual transmission
- Sawblade tension indication
- Tilttable work-table – 30° to the right, 15° to the left
- Exchangeable aluminium wheels with hard rubber coating
- Upper wheel adjustable
- Safety door switches on wheel doors
- Saw blade guide selectable: 1 set of jaw guides or 1 set of roller guides
- Possible tape dimensions: min. 3 mm x 0,65 mm to max. 13 mm x 0,9 mm
- Saw blade length 3200 mm
- 1 bi-metal saw blade
- 1 tool set
- The technical execution of our product complies with the machinery directive 2006/42/EG and is provided with CE mark
- Complete electrical design according to VDE
- Paint: RAL 7035 light grey, doors RAL 5005 signal blue

Technical specifications:

Voltage:	Volt/Hertz	400/50
(special voltages at extra charge)		
Cutting speed range:	m/min	12-1900
Wheel diameter:	mm	420
Table size:	mm	600 x 600
Table height:	mm	1020
Max. table payload:	kg	150
Cutting width:	mm	410
Cutting height:	mm	230
Motor power:	kW	2,2
	Volt/Hertz	230/400/50
	1/min	1500
Dimensions L x W x H:	mm	1215 x 750 x 1860
Net weight approx.:	kg	680

STEEL AND METAL BANDSAW MACHINES

MÖSSNER REKORD SSF420



Product pictures / drawings



Picture shows special equipment

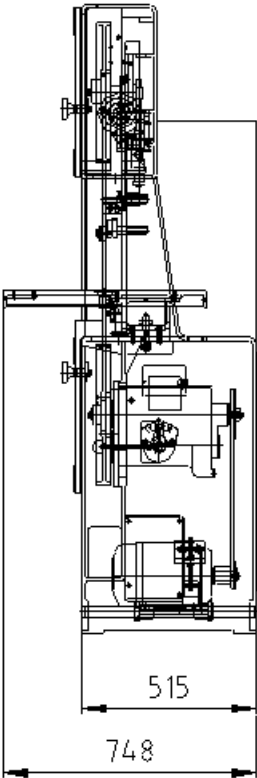
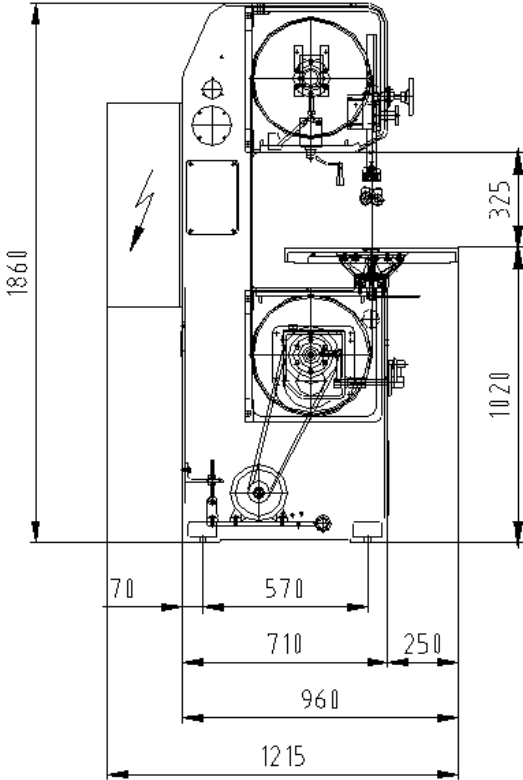

Top view

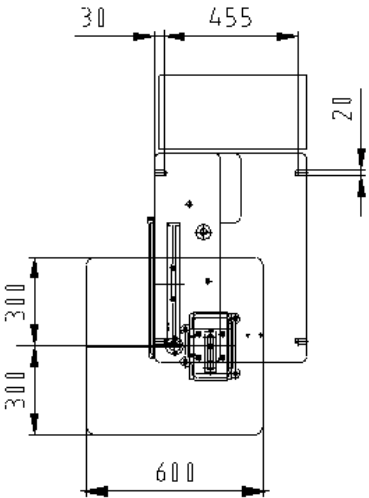

STEEL AND METAL BANDSAW MACHINES

MÖSSNER REKORD SSF520



Technical details:

- Bandsaw machine column in stable grey cast construction
- Cutting speed adjustable via frequency converter and three-phase motor with potentiometer *or* cutting speed infinitely variable with flange bearing and frequency converter
- 2-speed manual transmission
- Mechanical sawblade tension device with hydraulic indication
- Tilttable work-table – 30° to the right, 15° to the left
- Exchangeable aluminium wheels with hard rubber coating
- Upper wheel adjustable
- Safety door switches on wheel doors
- Saw blade guide selectable: 1 set of jaw guides or 1 set of roller guides
- Possible saw blade dimensions: min. 6 mm x 0,65 mm bis max. 27 mm x 0,9 mm
- Saw blade length 4600 mm
- 1 bi-metal saw blade
- 1 tool set
- The technical execution of our product complies with the machinery directive 2006/42/EG and is provided with CE mark
- Complete electrical design according to VDE
- Paint: RAL 7035 light grey, doors RAL 5005 signal blue

Technical specifications:

Voltage:	Volt/Hertz	400/50
(other voltage against extra cost)		
Cutting speed range transmission:	m/min.	22-150 and 338-2280
Cutting speed range flange bearing:	m/min.	500 - 2000
Wheel diameter:	mm	520
Table size:	mm	740 x 785
Table height:	mm	1058
Max. table payload:	kg	250
Cutting width:	mm	510
Cutting height:	mm	520
Motor power:	kW	5.5
	Volt/Hertz	400/690/50
	1/min	1500
Dimensions L x W x H:	mm	1565 x 970 x 2600
Net weight approx.:	kg	1100

STEEL AND METAL BANDSAW MACHINES

MÖSSNER REKORD SSF520



Product pictures / drawings



Picture shows special equipment

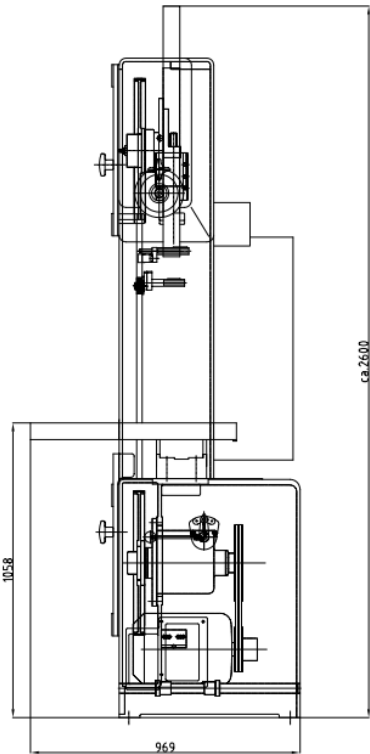
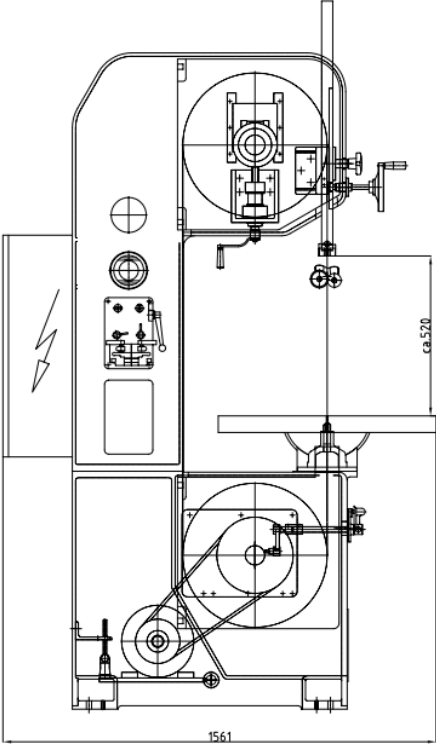

Top view

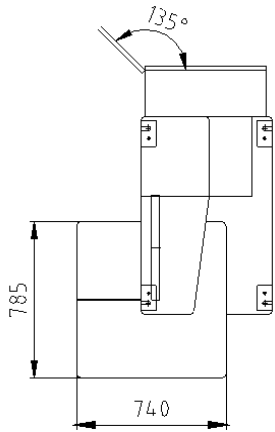

STEEL AND METAL BANDSAW MACHINES

MÖSSNER REKORD SSF630



Technical specifications:

- Bandsaw machine column in stable steel construction
- Cutting speed adjustable via frequency converter and three-phase motor with potentiometer *or* cutting speed infinitely variable with flange bearing and frequency converter
- 2-speed manual transmission
- Mechanical sawblade tension device with hydraulic indication
- Tilttable work-table – 30° to the right, 15° to the left
- Exchangeable aluminium wheels with hard rubber coating
- Upper wheel adjustable
- Safety door switches on wheel doors
- Saw blade guide selectable: 1 set of jaw guides or 1 set of roller guides
- Possible saw blade dimensions: min. 10 mm x 0,9 mm to max. 27 mm x 1,1 mm
- 1 bi-metal saw blade
- 1 tool set
- The technical execution of our product complies with the machinery directive 2006/42/EG and is provided with CE mark
- Complete electrical design according to VDE
- Paint: RAL 7035 light grey, doors RAL 5005 signal blue

Technical specifications:

Voltage:	Volt/Hertz	400/50
(other voltage against extra cost)		
Cutting speed range transmission:	m/min.	27-142 and 410-2200
Cutting speed range flange bearing:	m/min.	500-2000
Wheel diameter:	mm	630
Table size:	mm	740 x 785
Table height:	mm	1125
Max. payload table:	kg	250
Throat width:	mm	605
Throat height:	mm	460
Motor power:	kW	5,5
	Volt/Hertz	400/690 / 50
	1/min	1500
Dimensions L x W x H:	mm	1820 x 970 x 2560
Net weight approx.:	kg	1750

Optionally: Bandsaw in reinforced design

- Drive: 11 kW
- Sawblade width: min. 13 mm x 0,9 mm to max. 34 mm x 1,1 mm
- Reinforced flange bearing and reinforced hydraulic driven slide for sawblade tension
- Range of cutting speed shift transmission: 30-180 m/min. und 342-2000 m/min.,
Range of cutting speed flange bearing: 500-1900 m/min.

STEEL AND METAL BANDSAW MACHINES

MÖSSNER REKORD SSF630



Product pictures / drawings



Picture shows special equipment

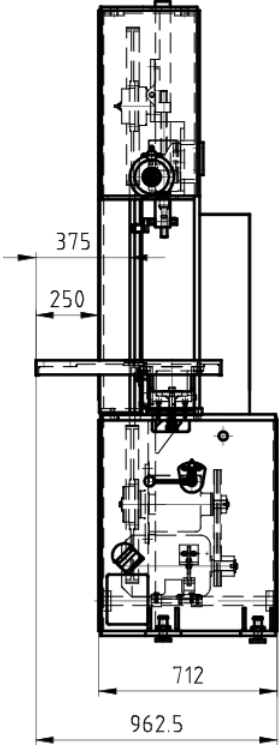
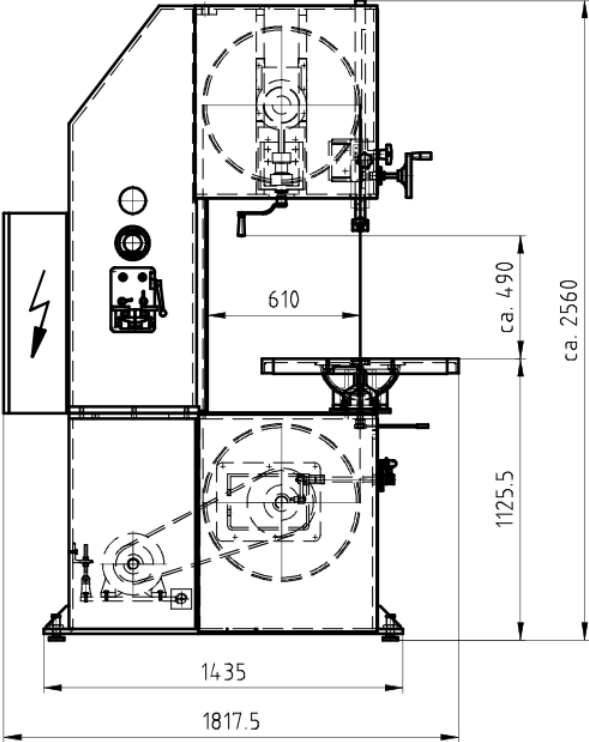

Top view

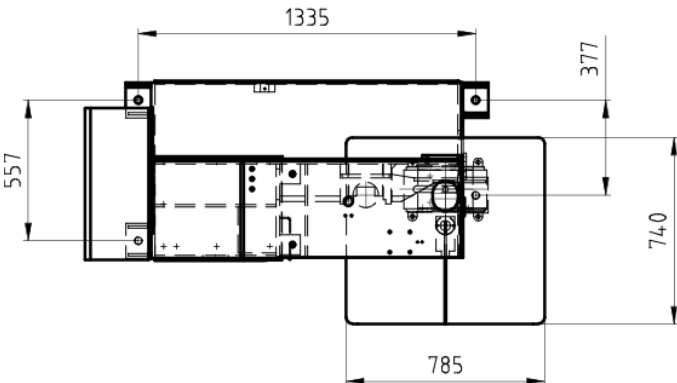

STEEL AND METAL BANDSAW MACHINES

MÖSSNER REKORD SSF801



Technical details:

- Bandsaw machine column in stable grey cast construction
- Cutting speed adjustable via frequency converter and three-phase motor with potentiometer *or* cutting speed infinitely variable with flange bearing and frequency converter
- 2-speed manual transmission
- Mechanical sawblade tension device with hydraulic indication
- Tilttable work-table – 30° to the right, 15° to the left
- Exchangeable aluminium wheels with hard rubber coating
- Upper wheel adjustable
- Safety door switches on wheel doors
- Saw blade guide selectable: 1 set of jaw guides or 1 set of roller guides
- Possible saw blade dimensions: min. 13 mm x 0,9 mm to max. 34 mm x 1,1 mm
- 1 bi-metal saw blade
- Emergency push-button
- The technical execution of our product complies with the machinery directive 2006/42/EG and is provided with CE mark
- Complete electrical design according to VDE
- Paint: RAL 7035 light grey, doors RAL 5005 signal blue

Technical specifications:

Voltage:	Volt/Hertz	400 / 50
(other voltage against extra cost)		
Cutting speed range transmission:	m/min.	26-180 and 290-2000
Cutting speed range flange bearing:	m/min.	500-2000
Wheel diameter:	mm	800
Table size:	mm	960 x 1000
Table height:	mm	1130
Max. table payload:	kg	750
Cutting width:	mm	785
Cutting height:	mm	670
Motor power:	kW	11
	Volt/Hertz	400/690/50
	1/min	1500
Dimensions L x W x H:	mm	2240 x 1080 x 3000
Net weight approx.:	kg	2300

STEEL AND METAL BANDSAW MACHINES

MÖSSNER REKORD SSF801



Product pictures / drawings



Picture shows special equipment

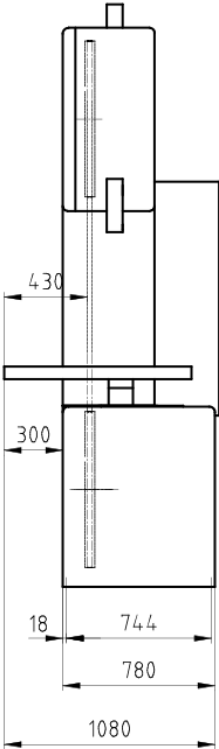
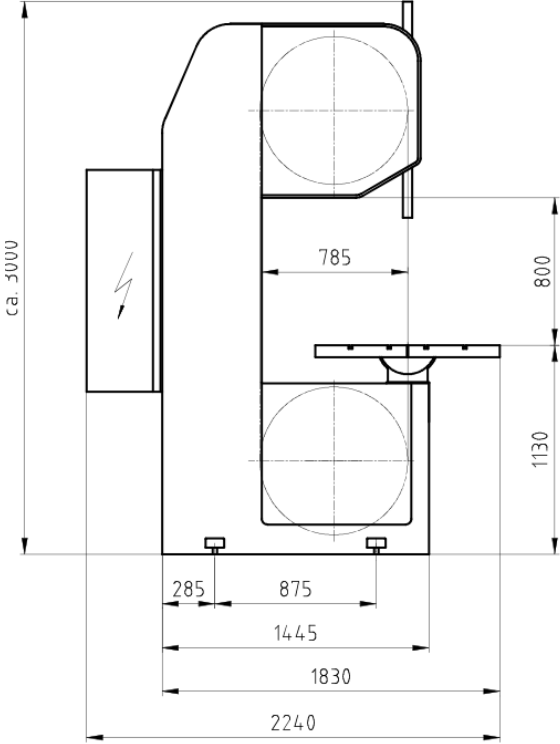

Top view

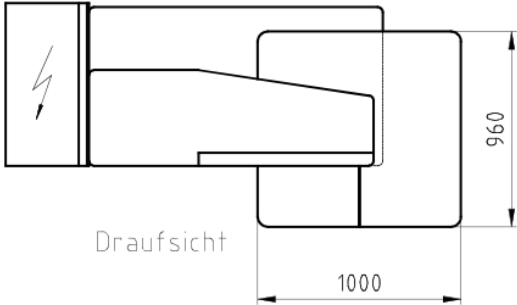

Draufsicht

STEEL AND METAL BANDSAW MACHINES

MÖSSNER REKORD SSF1600



Technical details:

- Bandsaw machine column in stable steel construction
- Cutting speed adjustable via frequency converter and three-phase motor with potentiometer *or* cutting speed infinitely variable with flange bearing and frequency converter
- 2-speed manual transmission
- Mechanical sawblade tension device with hydraulic indication
- Tilttable work-table – 30° to the right, 15° to the left
- Exchangeable aluminium wheels with hard rubber coating
- Upper wheel adjustable
- Safety door switches on wheel doors
- Swiveling control panel
- Saw blade guide selectable: 1 set of jaw guides or 1 set of roller guides
- Possible saw blade dimensions: min. 6 mm x 0,65 mm to max. 27 mm x 0,9 mm
- 1 bi-metal saw blade
- 1 tool set
- The technical execution of our product complies with the machinery directive 2006/42/EG and is provided with CE mark
- Complete electrical design according to VDE
- Paint: RAL 7035 light grey, doors RAL 5005 signal blue

Technical specifications:

Voltage:	Volt/Hertz	400/50
(other voltage against extra cost)		
Cutting speed range transmission:	m/min.	22-150 and 338-2280
Cutting speed range flange bearing:	m/min.	500-2000
Wheel diameter:	mm	520
Table size:	mm	740 x 785
Table height:	mm	970
Max. payload table:	kg	250
Cutting width:	mm	1600
Cutting height:	mm	400
Motor power:	kW	5,5
	Volt/Hertz	400/690/50
	1/min	1500
Dimensions L x W x H:	mm	3100 x 1060 x 2320
Net weight approx.:	kg	1850

STEEL AND METAL BANDSAW MACHINES

MÖSSNER REKORD SSF1600



Product pictures / drawings



Picture shows special equipment

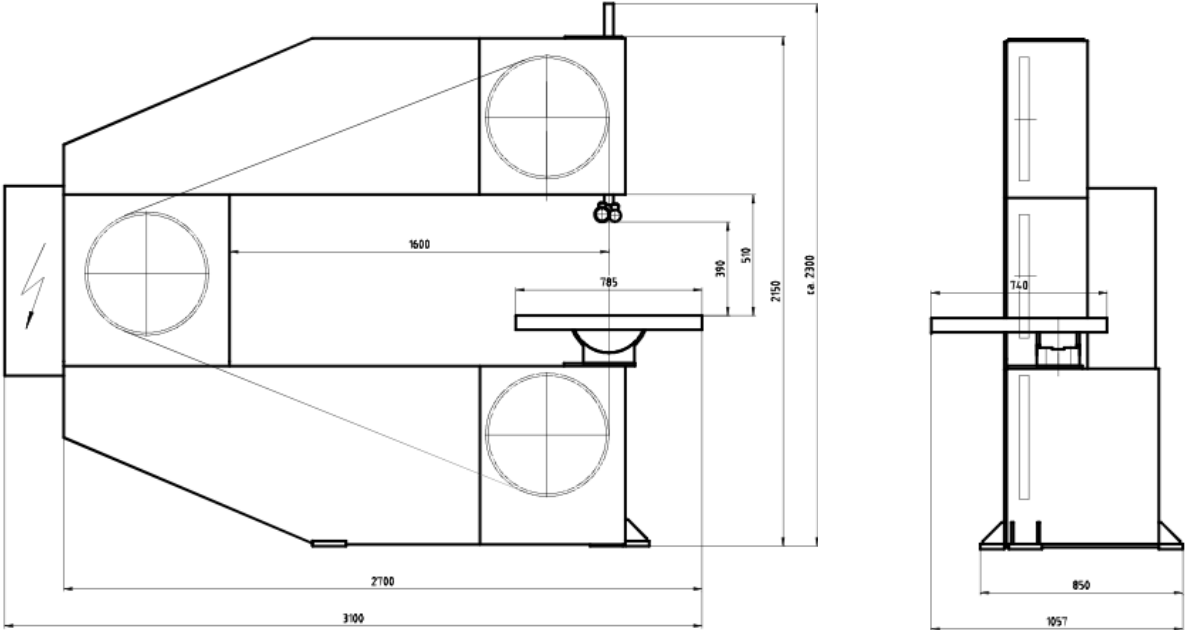

Top view

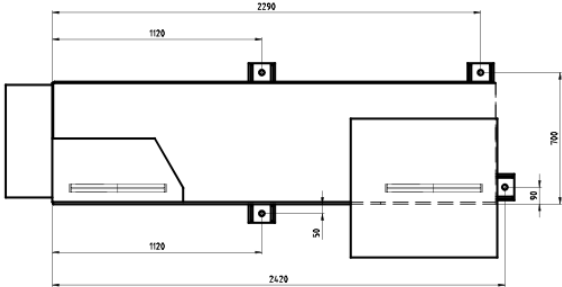

Butt welder

Butt welder EBS for sawblades, incl. shear and grinding motor.

Available EBS types:

- ⇒ For bandsaw type SSF420:
EBS16 for **max. 16 mm sawblade width**

- ⇒ For bandsaw types SSF520, SSF630, SSF1600:
EBS 25 for **max. 20 mm sawblade width**

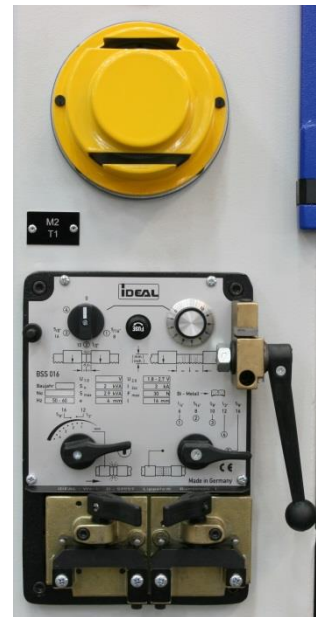

SAWBLADE GUIDANCE

(dimensions depending on sawblade)

Jaw guides with inserts

Jaw guides including exchangeable carbide-tipped guide inserts, available in different sizes.

Inserts for jaw guides

Carbide-tipped guide inserts for jaw guides



Roller guides

Roller guides including guide rollers for cutting speeds from 250 m/min., available in different sizes.

Guide rollers

1 set = 2 pieces with rim, 2 pieces without rim



Special roller guides for melting cuts

Special roller guides for melting cuts with 1 pair guidance rings for 20 mm wide sawblades (other sizes available on request).

SAFETY EQUIPMENT

Emergency push-button

Additional pedal switch for emergency stop.



Magnetic brake upper wheel

Automatic braking of the upper wheel by magnetic brake, in case of loss of tension or saw blade breakage.

For a SSF420 a mechanic band tension device with hydraulic indication is also required.

HELPFUL EQUIPMENT

Straight cutting device

(not available with feed table)

The straight cutting device is attached to the working table by means of 4 pins.

The feed can be done manually.

Following cuts can be done:

- Cuts with angle up to 45° by means of the angle stopper (adjustable to mitre)
- Cuts with length up to 230 mm by means of the adjustable length stopper
- Depth of cut can be limited with another stopper

Technical data:

Size: 400 x 400 mm

Feed way: 240 mm



HELPFUL EQUIPMENT

Parallel ledger

Parallel ledger consisting of:

- Scaled guide bar
- Guide cone with clamping
- Stopper lineal
- Adjusting range depending on machine type

Type SSF420	up to 290mm
Type SSF520/SSF630/SSF1600	up to 390mm
Type SSF801	up to 550mm



Workpiece holder

Workpiece holder for safe and exact guiding of the workpiece.

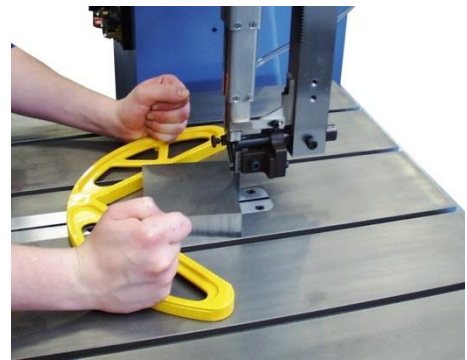

Cutting support device

The cutting support device is used to cut thin sheets with thickness up to approx. 6 mm.

Due to the small contact surface the sheet is prevented from vibrating and thus minimises the risk that teeth of sawblade break.



FEED TABLES STANDARD BANDSAW MACHINES

Feed tables

- Feed table with 4 T-grooves and wear parts
- Feed way depending on machine type
- Work table inclinable, to the right side approx. 8° and to the left side approx. 14°
- Instead of usual table execution

Available versions:

- Manual feed table with fixing (not available for type SSF801)
- Manual feed table with lead screw
- Electric feed table with servo motor and ball screw

In case an electric feed table is chosen for bandsaw type SSF420 the machine is additionally equipped with mechanic band tension device with hydraulic indication. Starting from size SSF520 the mechanic band tension is serially included.

<u>Feed way / Table sizes:</u>	Feed way approx.	Table size approx.
SSF420	230 mm	600x700 mm
SSF520, SSF630, SSF1600	350 mm	830x790 mm

Tables in other sizes can be quoted on request.

Examples:



Manual feed table SSF420, with lead screw



Electric feed table SSF420

SPECIAL EQUIPMENT FEED TABLES

One-Axis-Positioning Control

- Feed length is entered via keyboard
- Actual value shown on digital display
- Electronic routing with incremental encoder
- Automatic switch off of feed movement when pre-set measurements are reached
- Max. 10 programs with 10 lines each

OTHERS

LED lamp

LED lamp for lighting of the working area.



Minimum spray device

Minimum spray device for lubrication of saw blade with thin oil

Consisting of:

- 1 spray head
- pressure container for 1 l content (lubricant not included)



Mechanic sawblade tension device

(serially included starting from size SSF520)

Mechanic sawblade tension device with hydraulic indication instead of standard device.

Incl. switch-off of drive in case of sawblade breakage.



Blowing off device

Blowing off of chips at the sawblade.
Pressure air provided by customer.

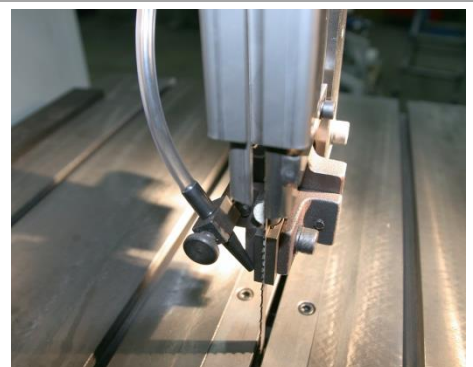

OTHERS

Alignment with laser

For exact positioning a laser beam projects a laser beam on the surface of the workpiece. This beam points out the cutting channel.

Used laser:

Helium-neon-laser with a prefixed line-optic, not dangerous for the eye (corneal reflex).



Connection piece for suction

Suction of chips at two points: lower sawblade guidance and lower wheel-box. Joined to 1 suction point for connection to suction system (by customer).

Design:

- Funnel with connection pieces under the working table, at the lower sawblade guidance
- Connection pieces in the lower wheel-box
- Housing of the drive wheel



Hydraulic sawblade tension

- Tension is activated by push button
- In case the saw blade tensioning drops / loosens the pre-set sawblade tension resets automatically
- When the machine is turned off, residual tension remains, to prevent the saw blade from sliding off the wheel



Swivelling control panel

(Starting from size SSF1600 the swivelling control panel is serially included)

Control panel with two pivotal points:

- Pivotal point 1 at the saw throat
- Pivotal point 2 at the operator's panel

The most important operating keys are integrated in the control panel. The main switch remains in the control cabinet.

Height of bottom edge operator's panel 1400 mm.



STEEL AND METAL BANDSAW MACHINES



PRICE LIST BANDSAW MACHINES

Valid from April 1st, 2022, to June 30th, 2022

Price adjustment due to world market situation only for band saws as of April 1st, 2022

Bandsaw Type	Price EUR without butt welder, shear and grinding motor	Price EUR with butt welder, shear and grinding motor
SSF420	16.440,00	18.370,00
	<i>17.590,00</i>	<i>19.660,00</i>
SSF520 shift transmission	24.920,00	26.970,00
	<i>26.660,00</i>	<i>28.850,00</i>
SSF520 flange bearing	24.120,00	26.170,00
	<i>25.860,00</i>	<i>28.050,00</i>
SSF630 shift transmission	30.770,00	32.820,00
	<i>32.920,00</i>	<i>35.110,00</i>
SSF630 shift transmission reinforced design 11 kW	40.720,00	on request
	<i>43.420,00</i>	
SSF630 flange bearing	29.970,00	32.020,00
	<i>32.120,00</i>	<i>34.310,00</i>
SSF630 flange bearing reinforced design 11 kW	37.770,00	on request
	<i>40.470,00</i>	
SSF801 shift transmission	53.400,00	on request
	<i>57.150,00</i>	
SSF801 flange bearing	50.450,00	on request
	<i>54.200,00</i>	
SSF1600 shift transmission	36.930,00	38.980,00
	<i>39.510,00</i>	<i>41.700,00</i>
SSF1600 flange bearing	36.130,00	38.180,00
	<i>38.710,00</i>	<i>40.900,00</i>

Max. sawblade width butt welder:

⇒ For type SSF420: EBS16 for **max. 16 mm sawblade width**

⇒ For types SSF520, SSF630, SSF1600: EBS 25 for **max. 20 mm sawblade width**

Packaging bandsaw machines

Bandsaw Type	Price EUR Packaging / crate	Price EUR Seaworthy packaging
SSF420	250,00	720,00
SSF520	390,00	1.180,00
SSF630	660,00	1.970,00
SSF801	770,00	2.240,00
SSF1600	920,00	on request

STEEL AND METAL BANDSAW MACHINES

PRICE LIST SPECIAL EQUIPMENT

Valid from July 1st, 2021 to June 30th, 2022



Sawblade guidance (dimensions depending on sawblade)	Bandsaw type	Price EUR
Jaw guides including carbide-tipped guide inserts, available in different sizes	SSF420	450,00
	SSF520, SSF630, SSF1600	515,00
Carbide-tipped guide inserts for jaw guides, available in different sizes, price per pair	All types	97,00
Roller guides including guide rollers	SSF420	780,00
	SSF520, SSF630, SSF1600	995,00
Guide rollers, price per set (1 set = 2 pcs. with rim, 2 pcs. without rim)	SSF420	496,00
	SSF520, SSF630, SSF1600	648,00
Special roller guidance for melting cuts with 1 pair guidance rings for 20 mm wide sawblades (other sizes available on request).	SSF520, SSF630, SSF1600	1.740,00
Guidance rings, price per set (1 set = 2 pcs. with rim, 2 pcs. without rim)	SSF520, SSF630, SSF1600	436,00
	SSF801	436,00

Wheels	Bandsaw type	Price EUR
Exchangeable aluminium wheels with vulcanized hard rubber coating, price per piece	SSF420	380,00
	SSF520, SSF1600	435,00
	SSF630, SSF801	1.215,00
Credit for worn wheels, if still usable and returned free of charge (per piece).	SSF420	145,00
	SSF520, SSF1600	190,00
	SSF630, SSF801	825,00

Safety equipment	Bandsaw type	Price EUR
Emergency push-button (serially included in SSF801)	All types	220,00
Safety magneto brake for undriven wheel	SSF420, SSF520, SSF630	820,00
	SSF 801	1.875,00
	SSF1600	1.640,00

STEEL AND METAL BANDSAW MACHINES

PRICE LIST SPECIAL EQUIPMENT

Valid from July 1st, 2021 to June 30th, 2022



Helpful equipment	Bandsaw type	Price EUR
Straight cutting device (not available with feed table)	All types	1.030,00
Parallel ledger	All types, except SSF801	535,00
Parallel ledger, one-side bearing	SSF801	2.260,00
Workpiece holder	All types	115,00
Cutting support device (without guide insert)	All types	78,00

Feed tables with 4 T-grooves Instead of standard table	Bandsaw type	Price EUR
Manual feed table with fixing (not available for type SSF801)	SSF420 230mm feed way	2.920,00
	520, SSF 630, SSF1600 350mm feed way	4.090,00
Manual feed table with lead screw	SSF420 230mm feed way	4.130,00
	SSF520, SSF 630, SSF1600 350mm feed way	5.790,00
Electric feed table with servo motor and ball screw	SSF420 230mm feed way	8.680,00
	SSF520, SSF 630, SSF1600 350mm feed way	9.970,00
Feed tables in other sizes		on request
One-Axis-Positioning Control	All types	3.690,00

STEEL AND METAL BANDSAW MACHINES

PRICE LIST SPECIAL EQUIPMENT

Valid from July 1st, 2021 to June 30th, 2022



Other equipment	Bandsaw type	Prices EUR
LED lamp	All types	285,00
Minimum spray device (lubricant not included)	All types	2.260,00
Special grease lubricant in 10 l package - price per litre 28,00 EUR (graduated prices available on request)	All types	280,00
Mechanic sawblade tension device with hydraulic indication instead of standard device. Incl. switch- off of drive in case of sawblade breakage.	SSF420 (serially included starting from size SSF520)	690,00
Electronic glow current regulation for welding unit (for voltage until 400 Volt, 50 Hertz)	All types, except SSF801	440,00
Blowing off device	All types	195,00
Alignment with laser)	All types	910,00
Swivelling control panel	SSF520, SSF630, SSF801, SSF1600	1.950,00
Hydraulic sawblade tension	SSF520, SSF630, SSF801	4.950,00
Connection piece for suction	SSF420, SSF520, SSF630, SSF801	1.480,00
Special colour (instead of standard machine colour)	SSF420	370,00
	SSF520	485,00
	SSF630, SSF801	615,00
	SSF1600	740,00
Enlarged throat of height by 250mm to 710mm	Only available for SSF630	2.260,00
Other voltage (additional price)	All types	380,00
Other voltage for butt welder (additional price)	All types	560,00

Sawblades	Bandsaw type	Prices EUR
Depending on material to be cut	All types	on request

Analysieren. Entwickeln. Machen.



Casting Technology

Sawing, Decoring, Deburring, Cooling, Finishing

Aluminium Technology

Sawing of Slabs, Blocks and Sheets

Bandsaw Machines

Standard Bandsaws and Individual Solutions

Nuclear Technology

Dismantlement of Nuclear Installations

August Mössner GmbH + Co. KG

Hohenstaufenstraße 3
73569 Eschach, Germany
Phone +49 (0)7175/99806-0
Fax +49 (0)7175/99806-35
www.moessner-kg.de
post@moessner-kg.de